

MANITOU NORTH AMERICA, INC.

WACO, TEXAS

For over 50 years MANITOU has been manufacturing equipment for the material handling industry. Based in Texas, MANITOU NORTH AMERICA manufactures and distributes vertical mast forklifts, MANISCOPIC telescopic handlers, MANITRANSIT truck mounted forklifts, and masts to dealers and OEM customers throughout North America.



MANITOU B.F.

As a pioneer of rough terrain forklifts MANITOU has always responded to market trends by designing truck ranges adapted to the specific needs of each industry. For each customer application there is a corresponding MANITOU forklift truck.

Currently there are more than 250,000 MANITOU rough terrain forklifts operating daily in more than 120 countries proving their efficiency and reliability.

This world wide presence is backed up by a MANITOU dealer network staffed with trained mechanics and sales specialists to help you with your material handling requirements.



MANITRANSIT

TRUCK-MOUNTED FORKLIFT

TMT 55FL-4W
Series



- 4-Way Steering
- One-side Unloading
- Lift Capacity: 5,500 lb.
- Maximum Lift Height: 135 in.
- Maximum Forward Reach: 58 in.
- Hydrostatic Transmission
- Three Wheel Drive

Front tires shown are not available in U.S.

Dealer:



MANITOU NORTH AMERICA, INC. - P.O. Box 21386 - Waco, TX 76702-1386
Tel: 800-433-3304 - Fax: 254-799-4433 - www.manitou-na.com



LOAD CAPACITY CHARTS

EQUIPPED WITH STANDARD 48" CARRIAGE AND 48" FORKS
(OPTIONAL ATTACHMENTS CAN DERATE THIS CHART)

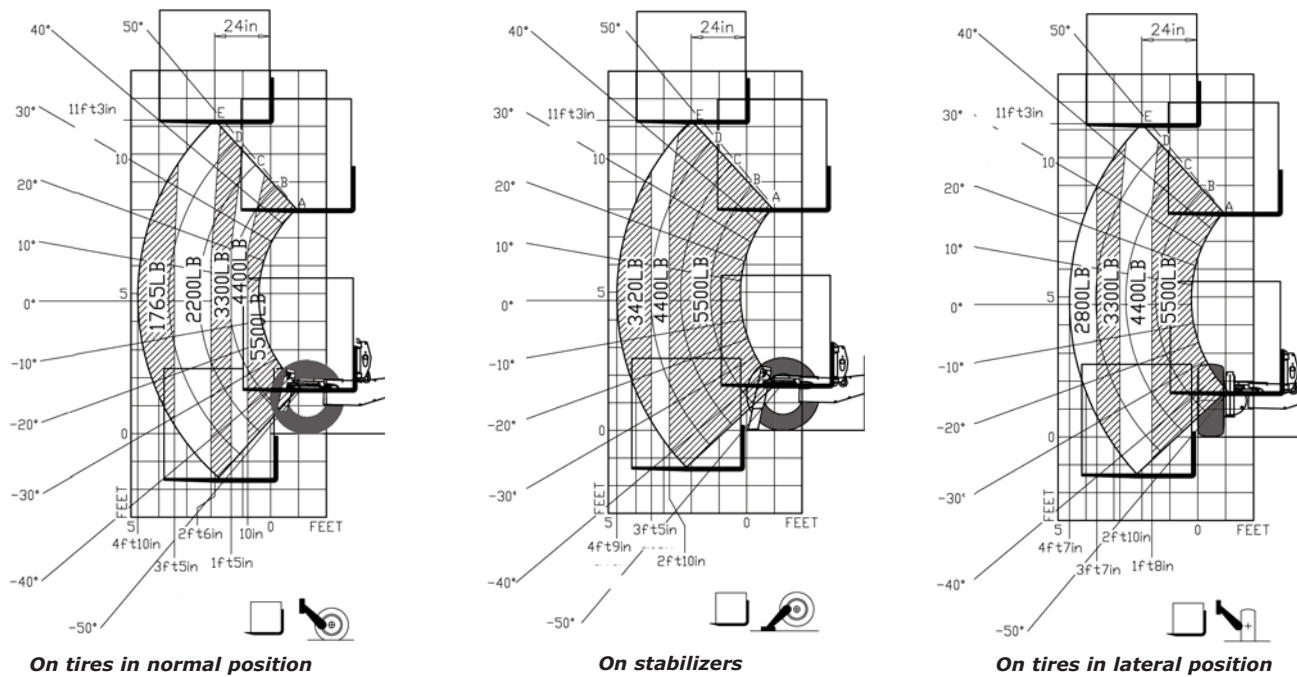



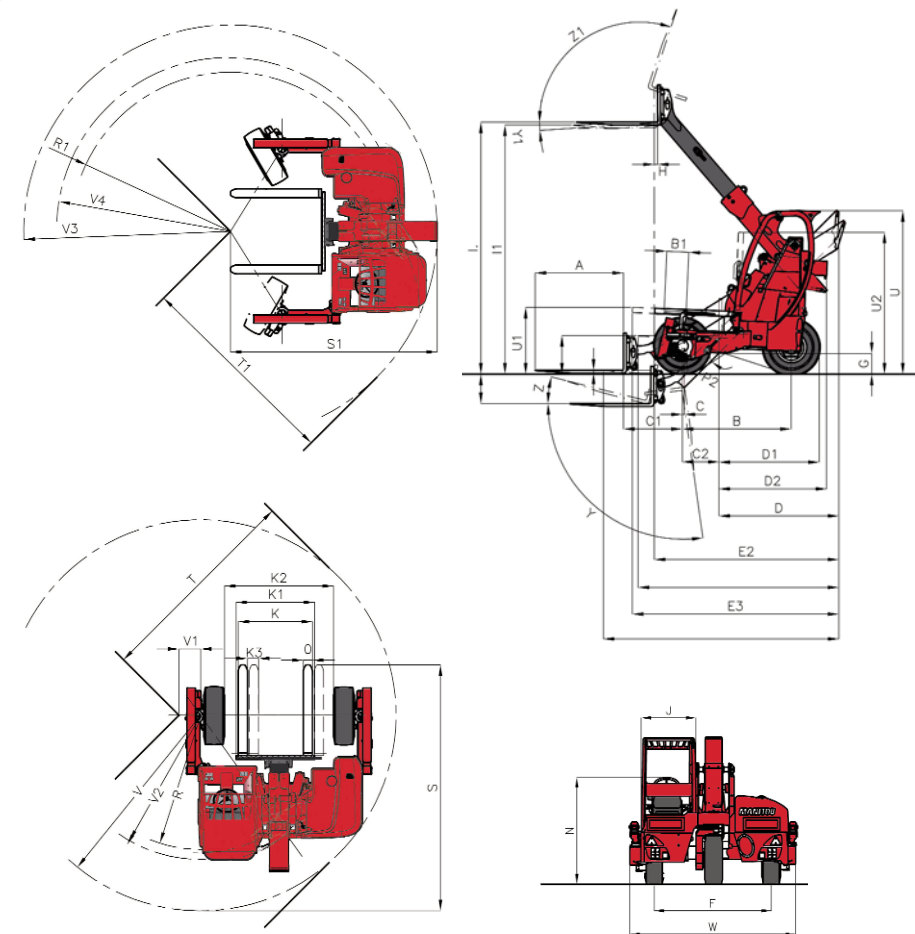







Capacities shown in pounds/feet are the maximum recommended load limits at the indicated extensions of the boom. Capacity ratings are based on a 48" homogeneous cube and are in accordance with ANSI/ASME B56.6 stability standards. Capacity reductions must be made for extended load centers and when used with various other attachments, contact MANITOU NORTH AMERICA, INC.



DIMENSIONS:

A.....48	M.....16
B.....58	M ₁20
B ₁12	N.....64
C.....1	O.....5
C ₁32	P ₂51°
C ₂20	R.....72
D.....64	R ₁85
D ₁53	S.....132
D ₂57	S ₁111
E.....130	T.....113
E ₁112	T ₁111
E ₂99	U.....87
E ₃110	U ₁36
F.....69	U ₂76
G.....11	V.....105
H.....2	V ₁12
I.....135	V ₂77
I ₁133	V ₃111
J.....32	V ₄87
K.....42	W.....98
K ₁42	Y.....98°
K ₂58	Y ₁3.7°
K ₃6	Z.....14°
L.....2	Z ₁108°

TMT 55FL-4W/FLXT-4W

-  **Lift Capacity**
Maximum (24 in. load center)5,500 lb.
-  **Lift Height:**
Maximum lift height.....135 in.
Maximum forward reach58 in.
-  **Tires:**
Front.....31x10-16.5
Rear.....31x10-16.5
.....(XT model) 31x15.5-15
-  **Forks:**
Length.....48 in.
Width x thickness.....4 in. x 1.75 in.
Carriage tilt.....108°
-  **Brakes:**
Service (pedal)Hydrostatic
Parking brakeNegative disc with electrical control
-  **Engine:**
TypePerkins 404C-22 Diesel
Displacement135 cu. in.
Horsepower (@3000 rpm)52
Maximum Torque (@1800 rpm).....105 ftlb.
.....(XT model) 142 ftlb.
InjectionIndirect
Cooling.....Water
-  **Transmission:**
TypeHydrostatic
Hydraulic reversing shift, full syncro
Maximum travel speed.....8 mph
-  **Hydraulics:**
Pump.....Gear type
Flow9.4 gpm
Flow divider with priority to steering
-  **Capacities:**
Cooling system3 gal.
Engine oil.....3 gal.
Fuel tank9 gal.
Hydraulic fluid8 gal.
-  **Specifications:**
Weight (without forks)6,000 lb.
.....(XT model) 6,355 lb.
Turning radius (outside wheels)103 in.
Overall height.....85 in.
Overall width.....96 in.
Overall length (without forks)115 in.
Overhang.....55 in.
Ground clearance.....10 in.

STANDARD EQUIPMENT:

- 50" ITA Class II Standard Carriage
- Ergonomic ROPS/FOPS Operator's Compartment
- 4-Way steering
- Stabilizers
- Full Instrumentation
- Differential Lock
- Service Brake
- Joystick Controls
- DOT Light Package with Hook Up Harness
- LED Lights
- Backup Alarm
- Side Shift

OPTIONAL EQUIPMENT:

- Load Backrest
- Rotating Beacon
- Turbo II Precleaner
- Spare Tire
- Supplemental Hydraulic Circuit
- Turf Tires
- Carriage Rollers
- Drywall Package

In addition to the 52 HP Perkins engine, the TMT 55FLXT 4W has optimum torque.



Enables you to unload your truck-trailer from one side only with excellent visibility, without additional attachment.

FNR JOYSTICK



This new boom control joystick now integrates the reversing shift function: the driver can keep one hand on the steering wheel and one hand on this joystick to operate any movement. Time saving and much better driving position.